

**INSTRUCTION MANUAL  
OF THE BOILER OPERATION CONTROL PANEL**

*Pellets*  
control



---

*Thank you for choosing our product. We are glad that you have made a really good choice. Every your comment concerning the device operation will be welcomed.*

The **Pellets control** boiler operation control is a modern microprocessor system, which controls not only the boiler, but also central heating and warm utility water.

A sophisticated operation algorithm and possibility of regulation of many parameters allow a very flexible adjustment to a concrete system.

An alphanumeric display significantly facilitates communication between the device and user and significantly simplifies operation.

## **PRECAUTIONS**

**Warning:** danger of electrical shock.

- Disconnect power supply in the electrical switchboard before mounting or dismantling.
- Please read the attached instruction manual carefully before beginning to use the device.
- Please keep this instruction manual for further reference.
- Please follow all rules and precautions provided in his instruction manual.
- Make sure that the device is not damaged. If you have some doubts, stop using the device and contact your supplier.
- Please contact your supplier if you have any doubts concerning the safe exploitation of his device.
- Pay special attention to all warning labels on the device casing and packaging.
- This device should be used according to its purpose.
- This device is not a toy; don't allow children to play with it.
- Never allow children to play with any part of any part of packaging of his device.
- Small parts, such as fastening screws, should be kept away of young children. The supplied unit may contain such elements which may be swallowed and impose a choking hazard.
- No mechanical or electrical changes should be made on the device. Such changes may cause inappropriate operation of the device which could be incompatible with the standards and impose a negative impact on the operation.
- No objects should be put inside the device through the apertures (for instance, through the ventilation apertures), as this may cause a short circuit, electrical shock, fire or damage to the device.
- Do not allow water, moisture and dust to get inside the device, as it may cause a short circuit, electrical shock, fire or damage to the device.
- A proper ventilation of the device should be ensured; ventilation apertures should not be blocked; free air circulation around the device should be ensured.
- The device is foreseen for assembly inside premises, unless it is adapted to work outside.
- The device should not be exposed to any shock or vibration.
- Before connecting the device, make sure, that the parameters of the energy supply matches the device specifications.
- To avoid electrical shock, the device should be connected to the electrical socket with a protective earthing pin. The earthing of the socket should be properly made by an authorized electrician.
- Before connecting the device, make sure, that this will not cause overload of the electrical circuit. Avoid connecting the device to the same circuit as engines and other appliances that generate pulse interferences (for instance. Washing machines, refrigerators, etc.)
- It is absolutely necessary to disconnect the device from the power supply before connection of any cables and peripheral appliances to the device.
- To fully disconnect the unit from the mains, unplug the power cord from the power outlet, especially when it is not intended to use for a longer time.
- The power supply cable should be protected from damages, and laid in a way so as to avoid trampling; no objects should be put on the cable.
- All connections made should be compatible with the electrical mounting scheme installation as well as with national or local rules on electrical connections.
- This device contains no parts which could be replaced by the user. All service operations except from cleaning and fuse replacement (when the device is disconnected from the power supply) and function adjustments should be carried out by authorized service shop.
- It is absolutely necessary to disconnect the device from the power supply before starting any maintenance operations.
- No benzine, solvents or other chemical agents should be used to clean the device housing in order to avoid damaging the housing. It is recommended to use a soft cloth.
- The device should not be used absolutely if the power supply cable is damaged. A damaged cable should be replaced by the repair shop with the one of the same parameters as original cable.

## **INSTALLATION**

### **General requirements:**

- Please read the attached instruction manual carefully before beginning to use the device.
- The person that undertakes to make assembly should have an appropriate technical experience.
- The connections made using a copper cable should be suitable for operation in the temperature up to +75°C.
- All connections made should be compatible with the electrical mounting scheme installation as well as with national or local rules on electrical connections.

### **Location:**

These devices are foreseen for inside assembly only. Please make sure that the chosen location meets the following conditions:

- The place of assembly should be free from excessive humidity and flammable or corrosive vapor.
- The device should not be assembled near powerful electrical apparatus, electrical machines or welding equipment.

- The ambient temperature in the mounting location should not be higher than 75°C or lower than -25°C . The humidity should range from 5% to 95%, without condensation.

## CONNECTION

The following may be connected to the execution module, according to the needs:

- warm utility water temperature sensor **CTN-02** [T<sub>cwu</sub>]
- outside temperature sensor **CTZ-01** [T<sub>zew</sub>]. This sensor should be mounted outside the building, away from sunrays and other sources of heat, above 0,5m from the ground.
- room temperature regulator **Auraton 1300** [Reg.pok]
- central heating circulation pump [CO]
- warm utility water circulation pump [CW]

## ACCESSORY EQUIPMENT

An **additional Pellets control operator's panel** may be attached to the driver; it may be mounted in another location, for instance, in the apartment for remote control of the system operation. Further information may be obtained from the firm estyma electronics. Please find the address in the last page of this instruction manual.

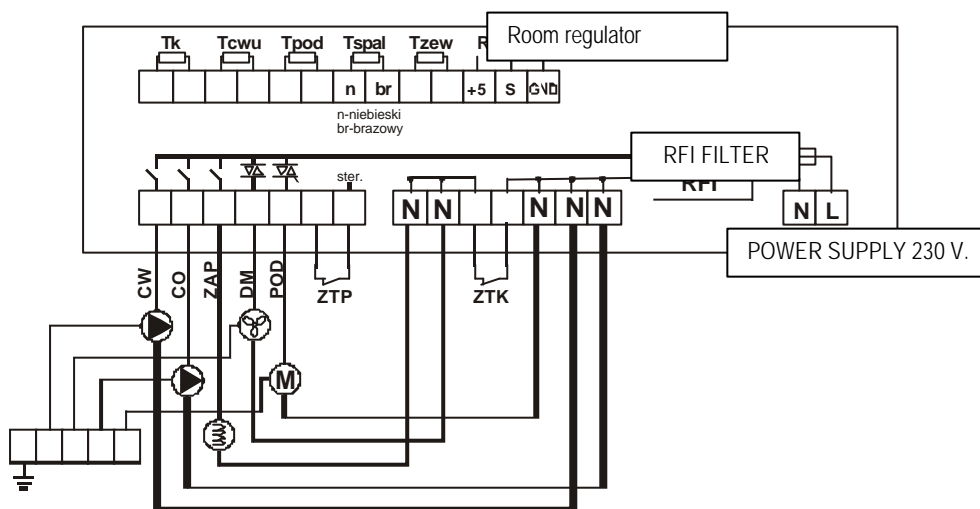

**Warning!!! Never connect the protection cable(PE) with the zero cable (N).**

- CW - warm utility water pump max.150W
- CO - central heating pump max.150W
- ZAP - electrical lighter max.400W
- DM - blower (fan) max.200W
- POD - feeder engine max.300W
- ZTP - feeder thermal protection
- ZTK - boiler thermal protection

Connections should be made with cables of 2,5mm<sup>2</sup> maximal diameter compatible with the electrical wiring. For the pump connection, the OMY 3x0,75 cable is recommended.

**WARNING !!!** The device should be connected to a separate electrical circuit equipped with an appropriate overcurrent protection switch and a differential current circuit breaker.

**WARNING !!!** The device should be disconnected from the power supply when making all connections. All connections should be made by a person appropriately authorized in this field.





Two types of menu are available in the device:

- the main menu, with capital letters, which may be scrolled by pressing the buttons „+” and „-” ; to enter a submenu, press the „F” button
- submenu, which May be scrolled in one direction by pressing the „F” button, the displayed values may be changed using the „+” and „-” buttons.

Data are saved every time after displaying the main screen: „TEMP.KOTLA” (“TEMPERATURE OF THE BOILER”).

**OPERATIONAL MODES OF THE BOILER**

Three modes are available in the boiler: weather mode (recommended), manual mode and summer mode.

**-the weather mode;** to operate in his mode, it is necessary to install the supplied CTZ-01 outside temperature sensor. The operational temperature of the boiler may be selected from the linear approximation of the programmable heating curve, so it is not necessary to change the temperature manually when the outside temperature changes. Nights are usually cooler than days. This is the operational temperature of the boiler in the function of outside temperature.

The user has to program two points on the curve, for the following outside temperatures: -20°C and -10°C.

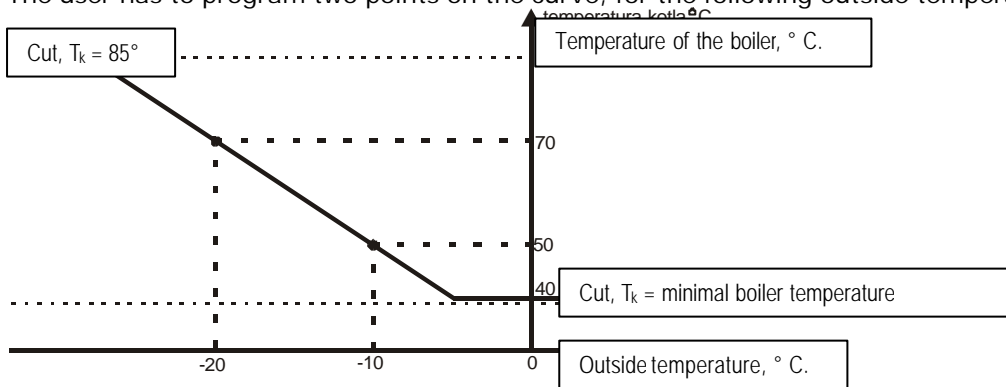

When it is necessary to heat the warm utility water, the operational temperature of the boiler is automatically changes in order to heat the utility water as soon as possible, and then returns to the operation according to the heating characteristics.

**-manual mode;** in his mode, the user sets the operational temperature of the boiler manually. When it is necessary to heat the warm utility water, the operational temperature of the boiler is automatically changes in order to heat the utility water as soon as possible, and then returns to the operation according to the temperature set by the user.

**- summer mode;** the driver does not activate the central heating pump, except of alarm situations; this mode is used in summer to heat the warm utility water.

**THE SET TEMPERATURE OF THE BOILER**

In the weather mode, the set operational temperature of the boiler is calculated from the heating characteristics, on the base of the outside temperature. In the summer and manual modes, the user enters the set temperature into the submenu „temp. zadana kotla” (“the set temperature of the boiler”).

**HYSTERESIS LOOP OF THE BOILER**

The hysteresis loop is a zone of insensitivity to temperature changes. The blower (feeder) turns off when the boiler reaches the set temperature, and turns on again when the boiler temperature falls by the set temperature of the boiler diminished by hysteresis.

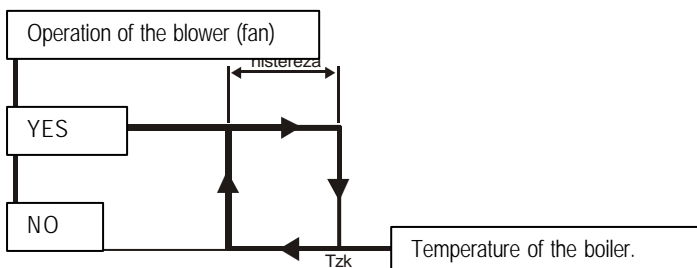

## **BRIGHTNESS OF THE DISPLAY**

User may adjust brightness of the display in the "display brightness" („jasnosc wyswietlacza") submenu. Display turns off automatically and may be turned on by any button.

## **POWER OF THE BURNER**

The user may choose between the following three levels of the burner operation if necessary:

- 3 – burner operates with 100% of power.
- 2 – burner operates with 60% of power.
- 1 – burner operates with 40% of power.

## **FEEDER OPERATION**

Operation of the feeder is programmed by the manufacturer in accordance with the boiler power.

## **AIR**

For a proper burning process, an appropriate quantity of air is necessary, which depends on the fuel type and device power. Therefore, an appropriate quantity of air should be set for every type of fuel and Power of the device. This should be done by the person who activates the device. These parameters will be saved in the fixed memory of the driver.

To do this:

- set the appropriate type of fuel
- set the burner power to the 1st degree
- activate the device
- in the "blower power No. 01" („dmuchawa przy mocy nr 01") submenu, adjust the air quantity using the buttons „+" and „-".

This action should be repeated for every value of the device power.

## **OPERATION OF THE PUMPS**

For proper and long-term operation of the boiler, an appropriate operational temperature is necessary. Therefore, circulation pumps may operate only after exceeding the minima temperature of the boiler operation. The value set by the manufacturer is 35°C.

## **WARM UTILITY WATER**

The Pellets heating boiler with the Pellets control panel perfectly suits for heating of warm utility water both within and outside the heating season.

The supplied CTN-02 sensor should be fitted to the reservoir of warm utility water.

In the "temperature set for the warm utility water" („temp.zadana c.w.u.") submenu, the temperature for the warm utility water should be set. This temperature shouldn't be too high, in order to minimize the losses of storage and transmission. The value set by the manufacturer is 45°C.

When the warm utility water should be heated, the temperature set for the boiler is the temperature set in the "temperature set for the warm utility water" („temp.zadana c.w.u.") submenu.

The regulator may operate in two modes of utility water heating (known from gas and oil boiler automatics thus far) with (recommended) or without priority for warm water. The settings should be made in the "warm utility water priority" („priorytet c.w.u.") submenu. In the case of the operation with priority, only the warm utility water pump turns on to heat the warm utility water, so that the water reaches the set temperature much faster.

To avoid the temperature fall in the apartment when the pump of warm utility water operates longer than 20 minutes (value set by the manufacturer) but the temperature set for the warm utility water has not been reached, the central heating pump will be turned on simultaneously for 5 minutes (value set by the manufacturer).

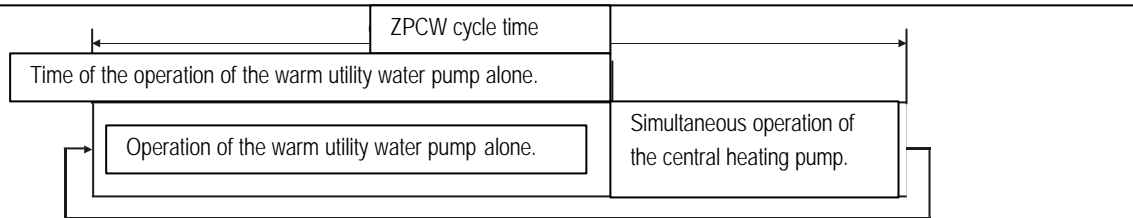

The warm water hysteresis loop is the parameter which decides on the moment of the warm water heating. When the water temperature in the reservoir falls below the set temperature diminished by hysteresis, the heating process begins. It is the same like in the case of the boiler hysteresis loop.

**ATTENTION!!!** When there is no separate pump for warm utility water or warm utility water reservoir, the temperature for the warm utility water should be set at 0°C in the regulator.

### ACTIVATION

Press the „Ó” button for 3 seconds to activate the device; the same should be done to turn off the driver. The current setting will be displayed in the main screen:

**OFF** – turned off (reaction to alarm situations and manual operation of the blower (fan) and feeder are active)

**ON** – turned on

**WARNING!!!** When the display shows OFF, the device operates in standby mode and is still under voltage; in the case an alarm situation will occur, the appropriate remedial processes will start (the pumps and feeder will turn on).

If the boiler is not intended to use for a longer time, or in the case of any works near the boiler, it is absolutely necessary to disconnect the device from the main supply.

The display (main screen) show the current settings of respective appliances. The displayed abbreviation will have the meaning of e of the device.

co – central heating circulation pump operation

cw – warm utility water pump operation

pod/zap – feeder or lighter operation

dm – blower (fan) operation

Boiler temperature: 60° C.



### THE FIRST KINDLING

When the feeder is used, after pouring the fuel to the reservoir, the feeder should be activated manually to carry the fuel to the combustion chamber. To do this, choose the “manual feeder operation” („praca ręczna podajnika”) submenu in the “ADVANCED SETTINGS” („USTAWIENIA ZAAWANSOWANE”) menu and press the „+” button to set “yes” („tak”). The feeder should work until half of the combustion chamber will be filled with fuel. Then press the „-” button to turn off the feeder. To activate the device, return to the main screen.

The kindling process is automatic and may last up to 30 minutes, according to the settings.

### ALARM SITUATIONS AND PROTECTIONS

By blinking display, the driver indicates that an alarm situation has occurred. After pressing the „F” button, information about the type of alarm will be displayed. The driver indicates the following alarm situations:

**-boiler overheating;** this alarm is indicated when the boiler temperature exceeds the „alarm temperature of the boiler“ („temperature alarmowa kotla“), set in the “SERVICE SETTINGS” („USTAWIENIA SERWISOWE”). Remedy in this case would be turning on of the circulation pumps irrespectively of the operation mode, until the boiler temperature turns down.

**-feeder overheating;** this alarm is indicated when the feeder temperature exceeds the „alarm temperature of the feeder“ („temperature alarmowa podajnika“), set in the “SERVICE SETTINGS” („USTAWIENIA SERWISOWE”).

**ATTENTION!!!** *If the alarm occurs, it is necessary to find the cause of the alarm situation and repair it.*

- **the protections are independent** from the microprocessor system operation. If the boiler or feeder temperature exceeds 94°C, an independent mechanical thermal breaker will start and the power supply to the blower (fan), feeder and lighter will be disconnected.

## **ROOM TEMPERATURE REGULATOR**

The Pellets driver may function together with any room temperature regulator with shorting contacts.

### **Intended use and general characteristics of the Auraton-1300 room temperature regulator**

The room temperature regulator is intended to function together with the microprocessor driver of the central heating boiler operation. The regulator allows to maintain a constant temperature in the room.

The room temperature should be set with the regulation crank (according to the instruction manual of the room temperature regulator). When the existing temperature is lower than the set temperature, the „HEAT“ icon appears. This is also a signal sent to the Pellets control driver indicating that the heat energy needs to be supplied to the room. The boiler activates and, if the other conditions are met, turns on the central heating pump.

The regulator should be mounted in a location representative as regards the apartment temperature, in the height about 1,5 – 2m.

### The room temperature regulator

Regulator pokojowy

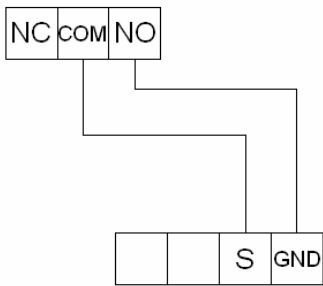

Regulator pracy kotła

The boiler operation regulator

The room temperature regulator should be connected with the driver using the OMY 2 x 0,75 cable.

NO- normally open

NC- normally closed

COM- common

S

- control signal

GND- power supply mass

The device should not be assembled near sources of heat (for instance, near TV or heaters), in locations exposed to direct sunrays or draughts as this may have a negative impact to the system operation.

## FACTORY SETTINGS

parameter	regulation range	factory settings
Set temperature of the boiler*	35-85°C	60°C
Set temperature of the warm utility water.	0-70°C	45°C
Hysteresis loop of the boiler	2-20°C	5°C
Hysteresis loop of the warm utility water	2-10°C	2°C
Temperature set for -20°C	40-85°C	70°C
Temperature set for -10°C	40-85°C	50°C
Priority of the warm utility water	yes; no	yes
Set power of the burner	1-3	3
Brightness of the display	0-10	10

\*the minimal set temperature of the boiler is adjusted in the service mode. The factory setting is 40°C.

## TECHNICAL DATA

Power supply	~ 230V/50Hz ±10%
Power consumption (by the driver)	< 5VA
Load capacity of the outlets	
Central heating pump	150W
Warm utility water pump	150W
lighter	400W
blower (fan)	200W
feeder	300W
Range of the boiler temperature adjustments	40-85°C
Range of the central utility water temperature adjustments	0-70°C
Precision of the temperature measurements	±4°C
Ambient temperature	0-60°C
Alarm temperature of the boiler	75-108°C
Alarm temperature of the feeder	0-150°C

The construction and technical data may be subjected to alterations.